



Universal Expandable Functional Test Platform



- Basic test need covered and ready to use
- 19" rack 23U high expandable with 9 U extra in robust aluminum profile with side ducts for all test wires trucking
- Power switch on sequence for low inrush current
- Safety power management
- 24VDC 200W power supply
- CAN bus control
- Rack temperature regulation with fan speed control

Standardizing a test system has never been so easy, fast and safe

The AS507 test system is based on a 19" frame of robust construction, suitable for an easy transport and it can integrate a height expansion module.

All management modules of the test system are preinstalled, so it is ready to include your instrumentation fast and easy.

The MMI and power management module provides electrical safety, 24VDC power and the Ethernet to CAN bus pass-through gateway. It manages the internal temperature of the rack, modulating the ventilation power.

The smart power distribution unit reduces effects of inrush current by connecting the devices in sequence and allows programming their connection to start the sequence.

AS507 supports tooling receivers from 6 to 25 contact modules (up to 5.952 contacts) or YAV switch cards.

The test management computer is powered by UPS to ensure data permanence even in micro outages or network failures.

The industrial PC has free PCI and PCIe slots in addition to the usual communication interfaces: LAN and USB.

To complete the configuration of the system, all that remains is to select and install the most appropriate instrumentation for the needs of the test to be carried out.

The option to expand the height unit allows to convert the general use test system into a more specialized one for particular needs.

Applications

General purpose functional, ICT or RF tests for electronics.

Order information

Item	Part Number
Universal Functional Expandable Test Platform 19" 23U	AS507
<ul style="list-style-type: none"> Industrial PC MMIPC17 Keyboard and Touchpad or Trackball 	
<ul style="list-style-type: none"> 350W UPS 	
<ul style="list-style-type: none"> Ethernet Router 	
<ul style="list-style-type: none"> Rack Power management with MMI H73000300 w/safety relay and 24VDC PSU 8-Sockets Smart Power Distribution Unit 	
Rack 19" 9 U High expansion unit	AM824
S6 VPC receiver with 15" Table mounted w/Rear cover, wiring retainers and modules guides	H72005100
G12 VPC receiver with 15" Table mounted w/Rear cover, wiring retainers and modules guides	H71007400
G18 VPC receiver with 15" Table mounted w/Rear cover, wiring retainers and modules guides	H72005300
9025 VPC receiver with 15" Table mount. w/Rear cover, wiring retainers and modules guides	H72005500
Sliding guides for receiver and fixture table	AR498
Drawer in the fixture table (VPC)	VP310113439
EU Layout Keyboard Touchpad	81G845500LUMEU2
21,5" 16:9 TFT Monitor with side adjustable support and keyboard holder	AH116
23,5" 16:9 TFT Monitor Tactil screen (w/out support)	AS383
19" TFT on 19" Rackmount 1280x1024 SXGA	AS558
Handheld 2D code reader	AK911
Code reader sidemount supporty	60IL207X
Emergency Stop kit	AN687
3-Color Status Light tower	H78001000

Spare parts and related products

Item	Part Number
YAV Modules	Under request
Stack & Rack instruments	Under request
Self-test fixture (Depending of ITA and integrated instruments)	Under request
VPC contact modules and Patch cords	Under request
3-Phase input control for 3-Phases DUTs	Under request



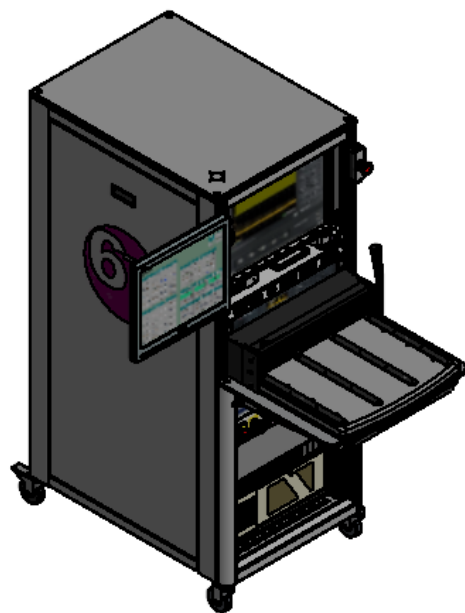
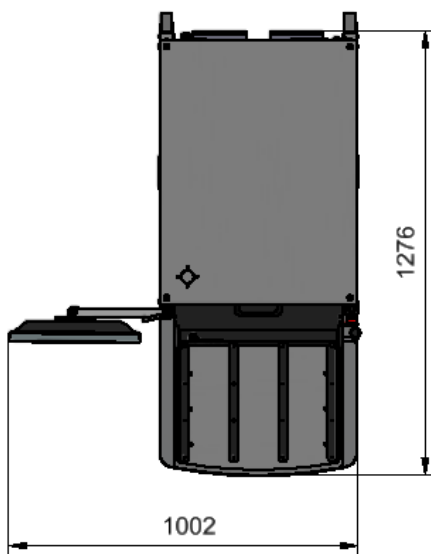
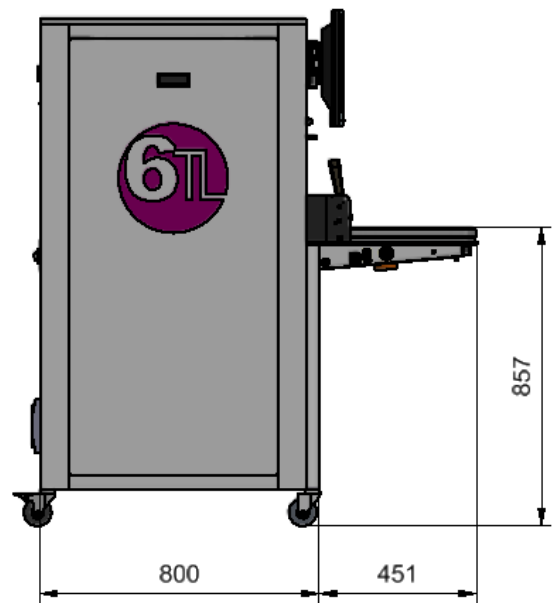
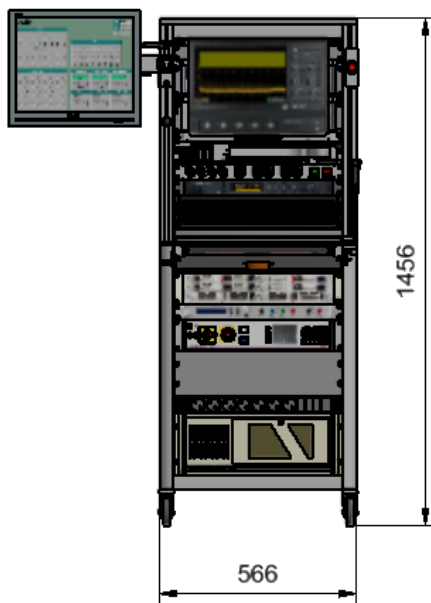

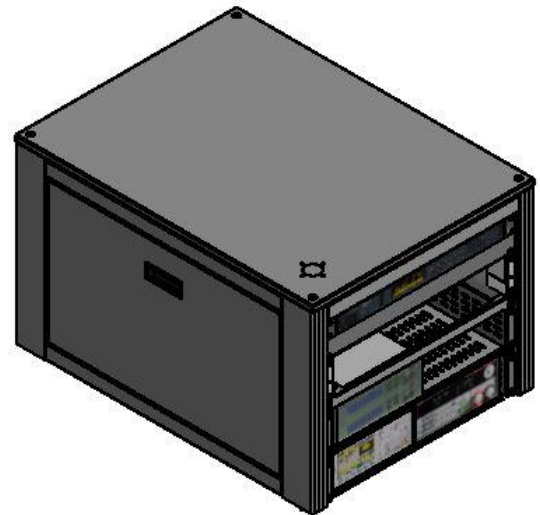
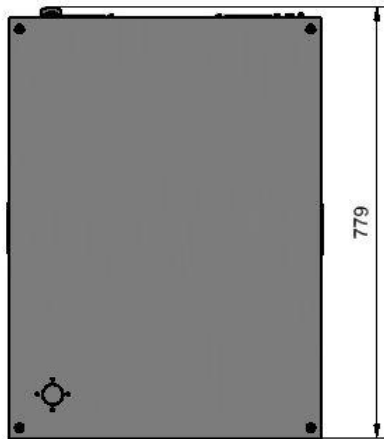
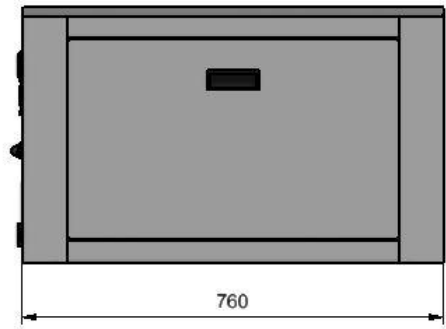
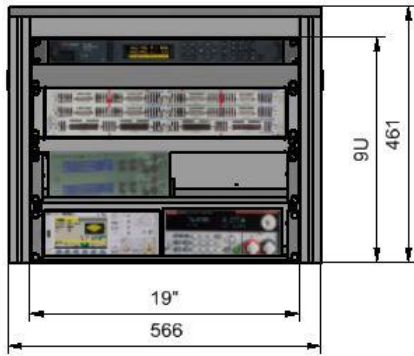
Dimensions







Autoweg 26
3911 TK Rhenen
The Netherlands
Phone +31-(0)317 398 787
Info@Romex.nl www.Romex.nl

-  ESD Solutions
-  Cleanroom Products
-  Soldering Equipment
-  Test & Measurement